



The most economical solution on the market

- Lowest price
- Simple to install
- Easy to use
- Low maintenance

SELECTED APPLICATIONS

Refining: light to heavy fuels, distillation bottoms, bitumen and asphalts

Lubricants, hydraulic fluids

Polymers: resins, high molecular weight additives

Whatever your industry, we understand and develop solutions for many applications. For a personalized approach, contact us at:

instruments@sofraser.com

AUTOMATED AND SIMPLE ANALYZER FOR ON-LINE VISCOSITY MEASUREMENT AT REFERENCE TEMPERATURE

With innovative functionalities and **9731** electronics, the **Thermoset-LT** is the most convenient and effective technology for viscosity measurement at reference temperature. Using the acclaimed advancements of the MIVI viscosity sensor, the **Thermoset-LT** brings the fluid to the required temperature and measures its viscosity in correlation with the ASTM D445 standard.

- **Guarantee product quality:** Thanks to reliable and repeatable measurements obtained continuously from the main process by-pass, the **Thermoset-LT** maintains strict manufacturing specifications.
- **Deliver optimal production efficiency:** With its simple installation in process operations, the **Thermoset-LT** has a small footprint, requires no side-systems and allows for outside installation.
- **Increase profitability:** An integrated bathless and ovenless flow-through cell guarantees minimal cleaning and maintenance related downtime. This asset provides tangible savings in both time and money while maximizing return on investment.
- **Technological versatility:** The **Thermoset-LT** processes myriads of parameters. It is highly tolerant to sample input temperature and is unaffected by the presence of particles, regardless of size. It is available for general purpose as well as classified areas. Associated with a density meter, it can measure kinematic viscosity and thus calculate viscosity index as described in the ASTM 2270-04.



Thermoset-LT – Process analyzer

In 1981, Sofraser invented and patented the world's first vibrating-type viscometer at resonance frequency and remains unsurpassed regarding process reliability and accuracy.

The active part of the sensor, a vibrating rod held in oscillation at resonance frequency, is driven by constant electrical power.

The vibration amplitude varies according to the viscosity of the product in which the rod is immersed.

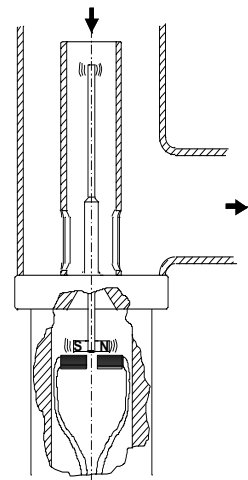

FEATURES AND SPECIFICATIONS

Measuring range	<ul style="list-style-type: none"> Selectable up to 10 000 cP at reference temperature (higher on request)
Precision	<ul style="list-style-type: none"> +/- 1% of reading (between 50% and 100% of full scale range)
Response time	<ul style="list-style-type: none"> 2 to 5 min (depending on input sample temperature and reference temperature)
Outputs	<ul style="list-style-type: none"> 5.7" LCD illuminated color touchscreen. Display of viscosity, temperature and density (option), 24 keys keypad & virtual keyboard 4-20 mA (viscosity, temperature, density) RS 485 – RS 232 Viscosity and temperature alarms and relays
Operating conditions	<ul style="list-style-type: none"> Maximum inlet temperature: 150 °C – 302°F (higher on request) Reference temperature: from 40 to 135 °C – 100 to 275 °F (according to inlet temperature) Maximum working pressure: 16 bar – 230 psi (higher on request)
Certification	<p><u>Analyzer</u></p> <ul style="list-style-type: none"> ATEX: II 2 G Ex IIB or II 3 G Ex IIB (temperature classification depending on fluid temperature) Class 1 Div 2 <p><u>Processor</u></p> <ul style="list-style-type: none"> IP66 – General purpose (To be placed in a safe area)
Process connections	<ul style="list-style-type: none"> Standard Swagelok® tube fittings Ø12mm or ANSI flanges (to be specified)
Required inputs	<ul style="list-style-type: none"> 110 or 240 VAC, single phase, 50-60 Hz, <100 W Compressed air: 7 bar, 0.5 m³/h – 100 psi, 0.3 SCFM Heating or cooling fluid (when required) Product flow rate: 60 l/h – 0.25 gpm suggested
Size and weight (standard)	<ul style="list-style-type: none"> <u>Analyzer</u> <ul style="list-style-type: none"> H: 600 mm – W: 600 mm – D: 250 mm – 60 kg approx. H: 2' – W: 2' – D: 10" – 130 lbs approx. <u>Processor</u> <ul style="list-style-type: none"> H: 400 mm – W: 300 mm – D: 200 mm – 10 kg approx H: 1'4" – W: 1' – D: 8" – 22 lb approx.
Options and Accessories	<ul style="list-style-type: none"> Density measurement for kinematic viscosity measurement in cSt Specific data logging on SD card Insertion of processor in an Ex-proof box Installation skid

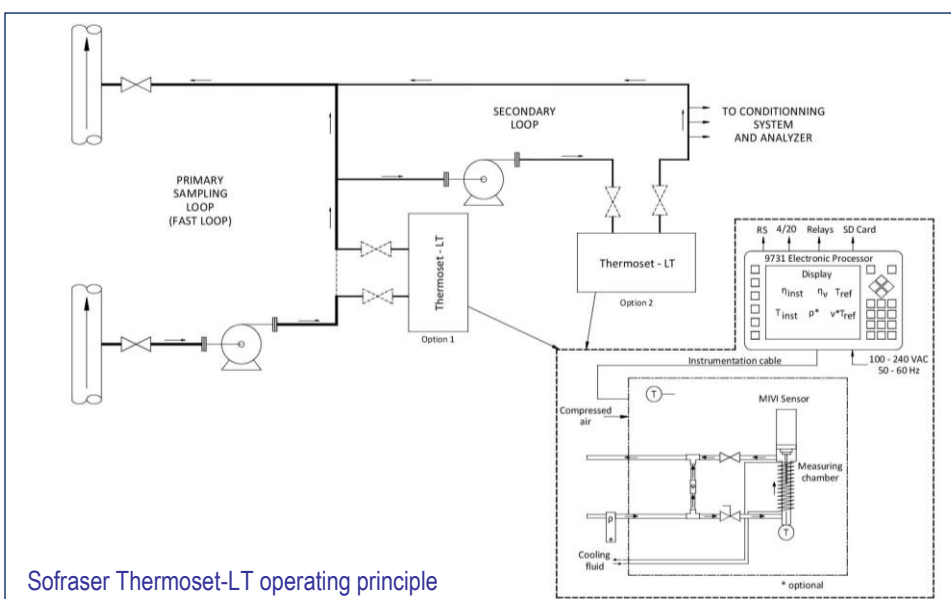

Sofraser Thermoset-LT operating principle

All conversions metric/imperial approximative
 Non contractual information
 Ref.352/0



SOFRASER

ZI, 15 rue Nobel
 45700 Villemandeur - France
 info@sofraser.com - www.sofraser.com
 +33 (0) 238 85 77 12 - Fax +33 (0) 238 85 99 65